

CREATING POWER SOLUTIONS.

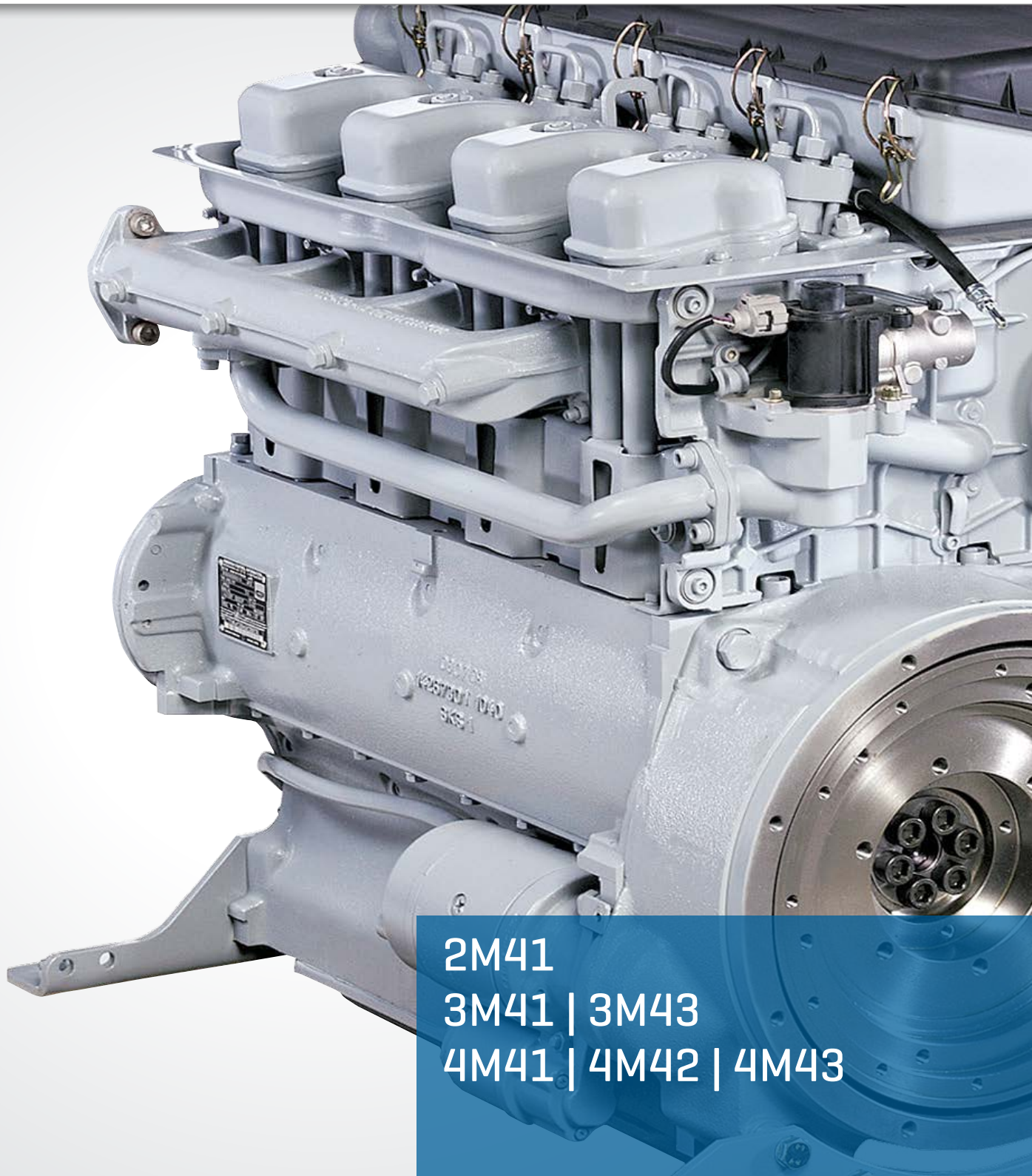

2M41
3M41 | 3M43
4M41 | 4M42 | 4M43

Hatz Diesel

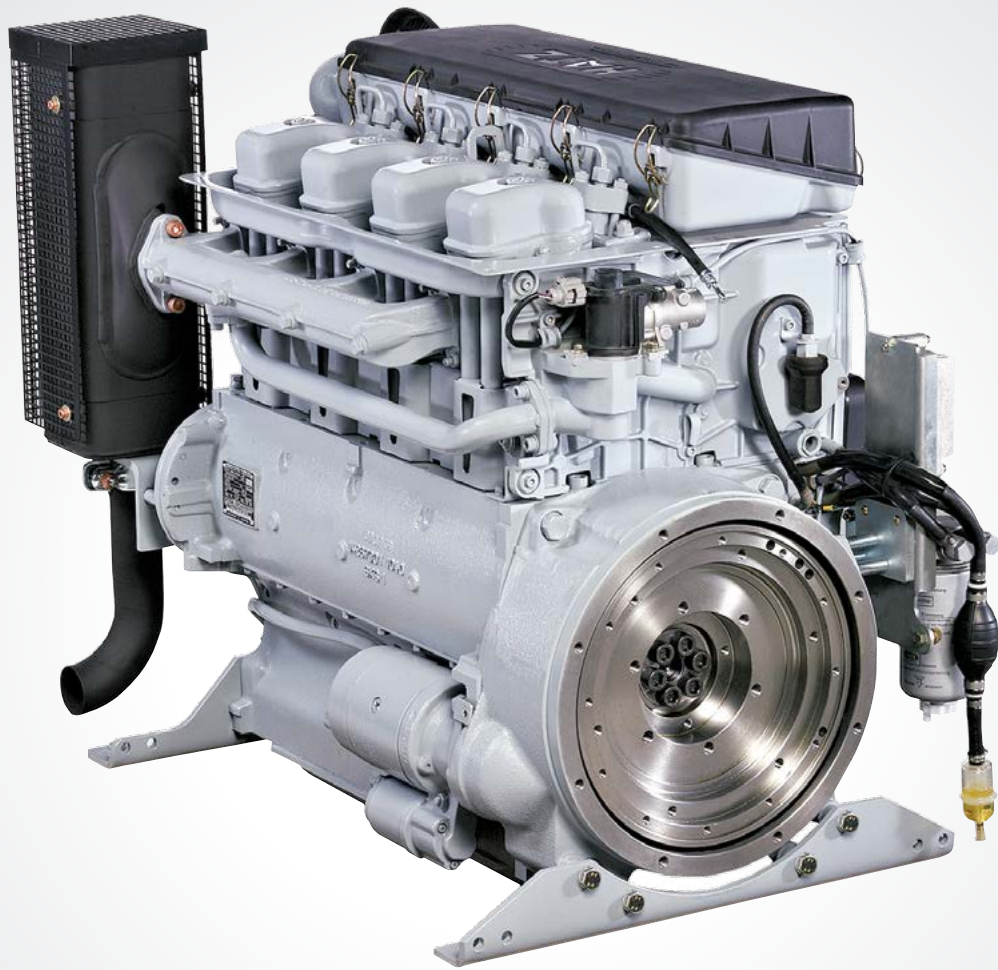

Simple operation

The M-series engines are fitted with an automatic hydraulic belt tensioner, self-bleeding injection pump, automatic cold start feed, and a signal transmitter for air filter maintenance as standard. Operation is also therefore easy even for non-specialists without long familiarization.

Diesel particulate filter

Hatz has developed a closed diesel particulate filter system with active regeneration in operation to give maximum flexibility to its customers. When the filter needs cleaning, it is fitted with quick fasteners for fast and non-destructive dismantling.

Hatz M-series: Always ready for operation

The Hatz M-series is the long-running success among the industrial diesel engines. The 2, 3 and 4 cylinder engines have been successfully established in the market for about 30 years - and they are still considered to be unbeatable. The rugged basic power train, above all the strongest crankshaft of all engines in the market, has remained unchanged since the market launch. So running times of many tens of thousands of hours are no problem for the engines in the Hatz M-series.

Environmental aspects

Hatz diesel engines in the L/M-series are the only exhaust-reduced, air-cooled engines available in this power range. The Hatz 4M42 with exhaust gas recirculation, the Hatz 3M43 as well as the Hatz 4M43 are also fitted with an electronic speed regulator and separable diesel particulate filter. Engines in the Hatz M43-series fulfill the strict emission standards of EU regulation 97/68/EC Stage IIIB as well as the regulations of the US EPA Tier 4 final.

Fuel consumption and cold start

M-series engines are among the most efficient in the market. Fuel consumptions of 212 grams per kilowatt hour testify to the optimized combustion process. 6-hole VCO nozzles, as well as the monoblock single pumps, and the optimized combustion chamber geometry all make their contribution to this. Without a pre glow system the engines start reliably as low as -10 °C; with a pre glow system and corresponding resources even -32 °C is no problem.

Unique automatic engine protection

The integrated, intelligent, mechanical automatic engine protection protects the engine. When a cooling fan malfunctions, there is not enough oil, or the inclination is too high, the engine is automatically stopped to prevent engine damage.

Maintenance and repair with little effort

All necessary points for oil and air filter service as well as for valve adjustment are easily accessible from the outside. This facilitates and speeds up the maintenance significantly. The M-series is built with a modular construction principle. Length-independent components such as cylinder heads, cylinders, conrods, bearing shells, injection nozzles, injection pumps, air filters, engine regulators, starter, and alternator are identical for all engines. Engine repair is easier and more cost effective. Furthermore, storekeeping for wearing parts is much easier to organize.

Robust and durable design



Hatz engines are designed for an exceptionally long service life. The best possible materials and components coupled with uncompromising quality assurance contribute to the fact that Hatz engines have been setting

the benchmark in the industry for many years when it comes to robustness and service life. And should, contrary to expectations, a spare part actually be needed, more than 500 service partners in 120 countries are available quickly and dependably with advice and assistance as well as original spare parts.

Sales area [exhaust certificate]	[rpm]	IFN rating ICFN rating F/IFN/ICFN rating					
		2M41	3M41	3M43	4M41	4M42	4M43
USA [EPA/CARB constant speed]		1500-2000	-	1500-3000	-	-	1500-3000
USA [EPA 2-speed]		1500-2000	-	-	-	-	-
USA [EPA variable speed]		2000	-	1500-3000	-	-	1500-3000
EU [constant speed]		1500-3000	1500-3000	-	1500-1800	1800-3000	-
EU [variable speed]		1500-3000	1500-3000	-	1500-1800	-	2200-3000
India CPCB I [Genset]		1500	1500	-	1500	-	-
All others [non-EPA]		1500-3000	1500-3000	-	1500-3000	-	-

Technical data, performance table

Technical data		2M41	3M41	3M43	4M41	4M42	4M43
Type	Air-cooled 4-stroke diesel engine with direct injection						
Number of cylinders	2	3	3	4	4	4	
Exhaust gas after-treatment	—	—	EGR & DPF	—	EGR	EGR & DPF	
Bore x stroke (mm / inches)	102 x 105 4.02 x 4.13	102 x 105 4.02 x 4.13	102 x 105 4.02 x 4.13	102 x 105 4.02 x 4.13	102 x 105 4.02 x 4.13	102 x 105 4.02 x 4.13	
Displacement (l / cu.in.)	1.716 / 104.7	2.574 / 157	2.574 / 157	3.432 / 209.4	3.432 / 209.4	3.432 / 209.4	
Mean piston speed at 3000 rpm (m/s ft/min)	10.5 / 2.067						
Compression ratio	20.0 : 1	20.0 : 1	20.8 : 1	20.0 : 1	20.8 : 1	20.8 : 1	
Lub. oil consumption, related to full load	max. 1 % of fuel consumption						
Oil filling max / min (l / US qts)	5.5 / 3.0 5.8 / 3.2	8.5 / 5.0 9.0 / 5.3	8.5 / 5.0 9.0 / 5.3	14.0 / 5.0 14.8 / 5.3	14.0 / 5.0 14.8 / 5.3	14.0 / 5.0 14.8 / 5.3	
Speed control							
· Lowest idle speed rpm	900	900	1.000	900	1.000	1.000	
· Static speed droop	approx. 5% at 3000 rpm						
Amount of combustion air at 3000 rpm approx. ¹⁾ (m ³ /min / cu.ft./min)	2.6 / 92	3.9 / 138	3.9 / 138	5.2 / 184	5.2 / 184	5.2 / 184	
Amount of cooling air at 3000 rpm approx. ¹⁾ (m ³ /min / cu.ft./min)	29 / 1.024	39 / 1.377	39 / 1.377	49 / 1.730	49 / 1.730	49 / 1.730	
Mass moment of inertia J (kgm ² / lb.ft ²)							
· SAE-flywheel 8"	0.64 / 15.2	0.65 / 15.4	0.65 / 15.4	0.67 / 15.9	0.67 / 15.9	0.67 / 15.9	
· flywheel for F+S clutch	0.49 / 11.6	0.50 / 11.9	0.50 / 11.9	0.51 / 12.1	0.51 / 12.1	0.51 / 12.1	
Starter	12 V - 2.7 kW — 24 V - 4.0 kW						
Alternator charging current at 3000 / 1500 rpm	14 V - 60 A / 42 A — 28 V - 40 A / 28 A						
Battery capacity (min / max Ah)	12 V - 88 / 143 Ah — 24 V - 55 / 110 Ah						
Engine with heavy flywheel (kg / lbs.)	294 / 648	— / —	— / —	— / —	— / —	— / —	
Engine with electric start 12 V or 24 V (kg / lbs.)	258 / 569	308 / 679	310 / 683 ²⁾	373 / 822	378 / 833	378 / 833 ²⁾	

¹⁾ For other speeds there is a linear reduction in the air requirement.

²⁾ Weight without diesel particulate filter.

Performance Table ³⁾		(rpm)	2M41	3M41	3M43	4M41	4M42	4M43
Vehicle power acc. to DIN ISO 1585 (kW / hp)	3000		28.3 / 38.5	43.3 / 58.9	— / —	57.5 / 78.2	— / —	— / —
	2600		26.9 / 36.6	40.6 / 55.2	— / —	53.8 / 73.2	— / —	— / —
	2300		25.3 / 34.4	38.1 / 51.8	— / —	51.0 / 69.4	— / —	— / —
Blocked ISO brake horsepower (IFN) for heavily intermittent loading acc. to ISO 3046-1 (kW / hp)	3000		26.3 / 35.8	39.8 / 54.1	36.6 / 49.8	53.1 / 72.2	51.5 / 70.0	49.9 / 67.9
	2600		25.0 / 34.0	37.8 / 51.4	34.9 / 47.5	50.6 / 68.8	48.0 / 65.3	46.1 / 62.7
	2300		25.4 / 34.5	38.9 / 52.9	35.1 / 47.7	52.0 / 70.7	47.6 / 64.7	45.7 / 62.1
	2000		22.4 / 30.5	34.5 / 46.9	31.4 / 42.7	46.0 / 62.6	42.4 / 57.7	41.2 / 56.0
	1800		20.2 / 27.5	31.1 / 42.3	28.4 / 38.6	41.3 / 56.2	38.6 / 52.5	37.2 / 50.6
	1500		16.4 / 22.3	25.0 / 34.0	23.2 / 31.5	34.0 / 46.2	— / —	30.5 / 41.5
ISO standard power output (ICXN) [10% overload permissible] (kW / hp)	3000		23.7 / 32.2	35.8 / 48.7	— / —	47.8 / 65.0	— / —	— / —
	2600		22.5 / 30.6	34.0 / 46.2	— / —	45.5 / 61.9	— / —	— / —
	2300		22.9 / 31.1	35.0 / 47.6	— / —	46.8 / 63.6	— / —	— / —
Blocked ISO standard power output (no overload permissible) acc. to ISO 3046-1, (kW / hp) For constant speed and constant load (ICFN)	2000		20.2 / 27.5	31.1 / 42.3	— / —	41.4 / 56.3	— / —	— / —
	1800		18.2 / 24.8	28.0 / 38.1	— / —	37.2 / 50.6	— / —	— / —
	1500		14.8 / 20.1	22.5 / 30.6	— / —	30.6 / 41.6	— / —	— / —

³⁾ Version „Z“ with counter balance shaft: power reduction about 0.3-1.5 kW depending on cylinder and speed.

Power, torque and fuel consumption

2M41

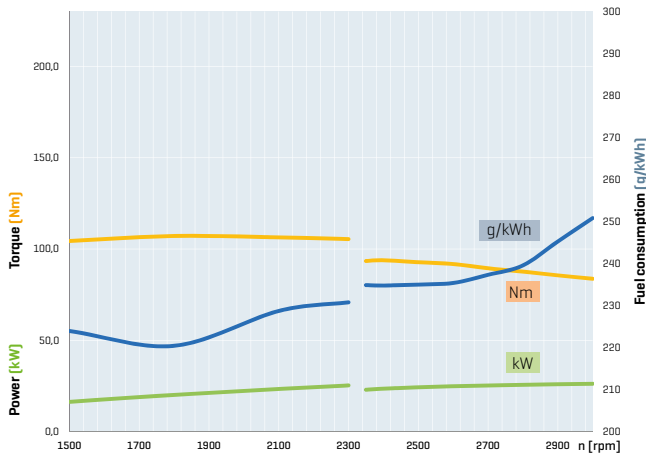

Power ratings

For the power ratings, refer to standard reference conditions of ISO 3046-1 (IFN): + 25 °C (77 °F), 100 kPa, relative humidity 30 %. The specified power is reached during the running-in period, and can be 5 % less on delivery. Power reduction acc. to ISO 3046-1. Standard values: More than 100 m above sea level approx. 1 % per 100 m. Above 25 °C approx. 4 % per 10 °C. The power taken from the alternator also has to be added to the power calculation.

3M41

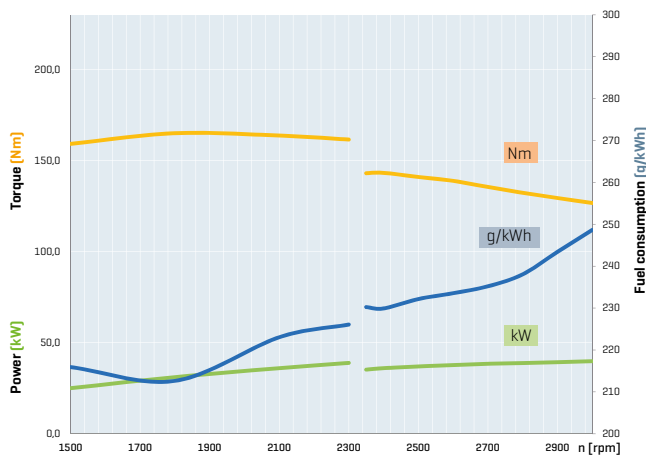

3M43

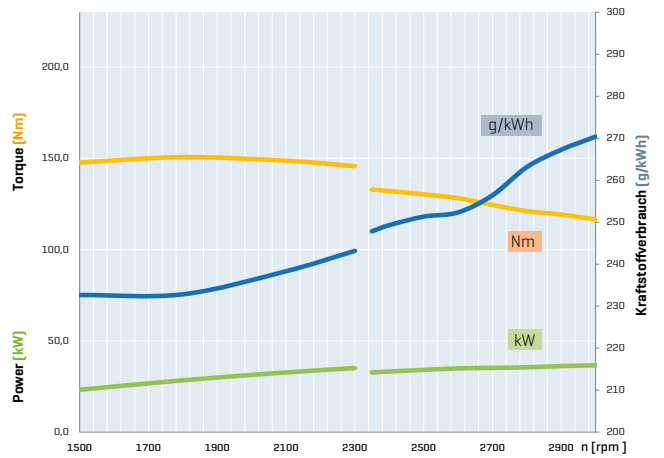

4M41

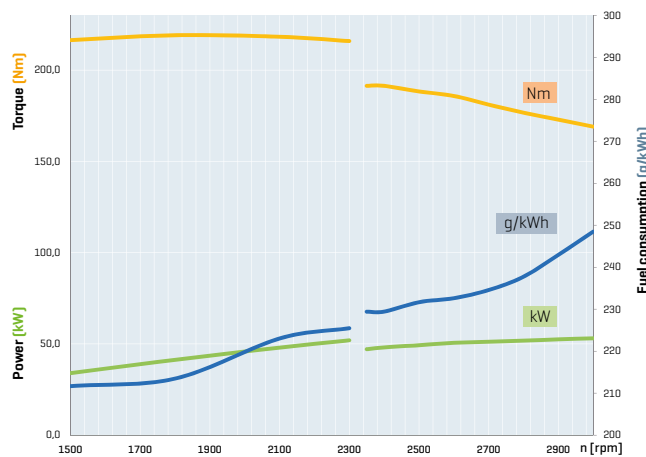

4M42

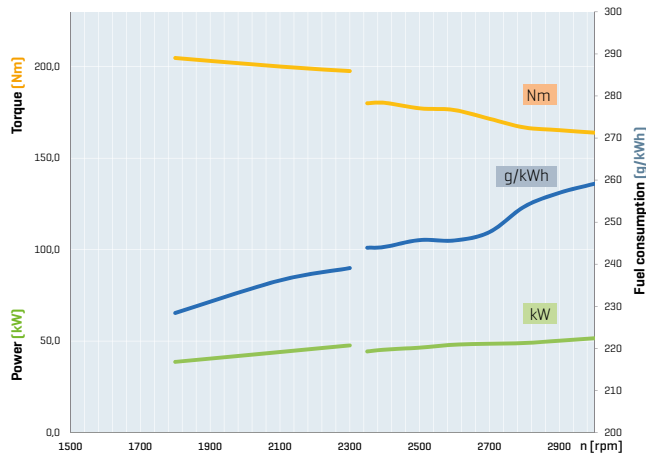

4M43

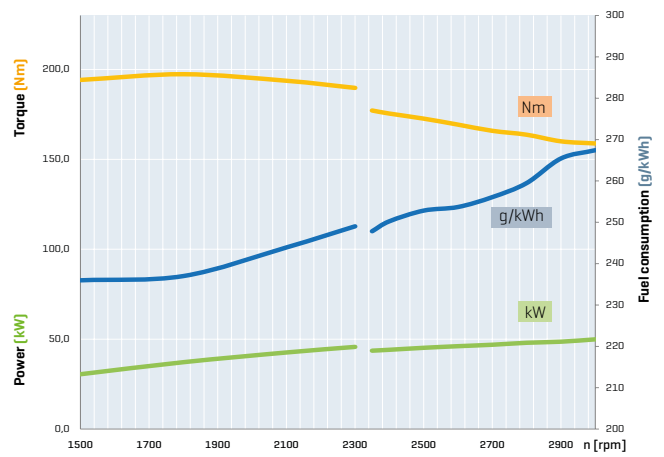

Maintenance and operating points

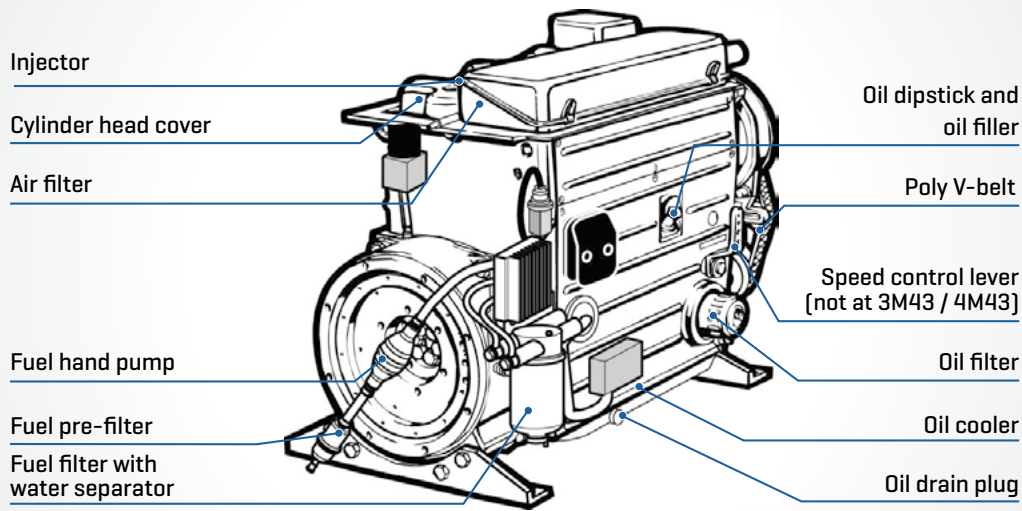
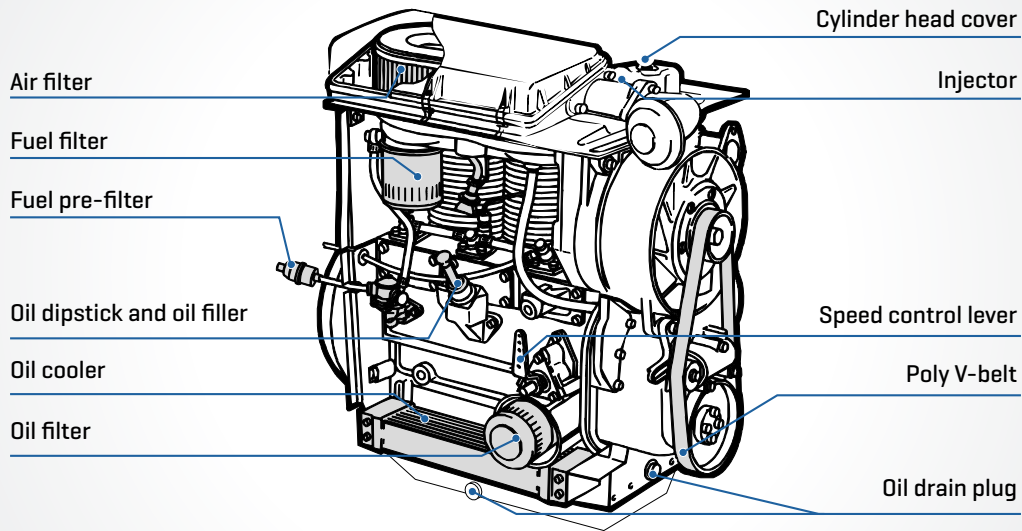

Power take off

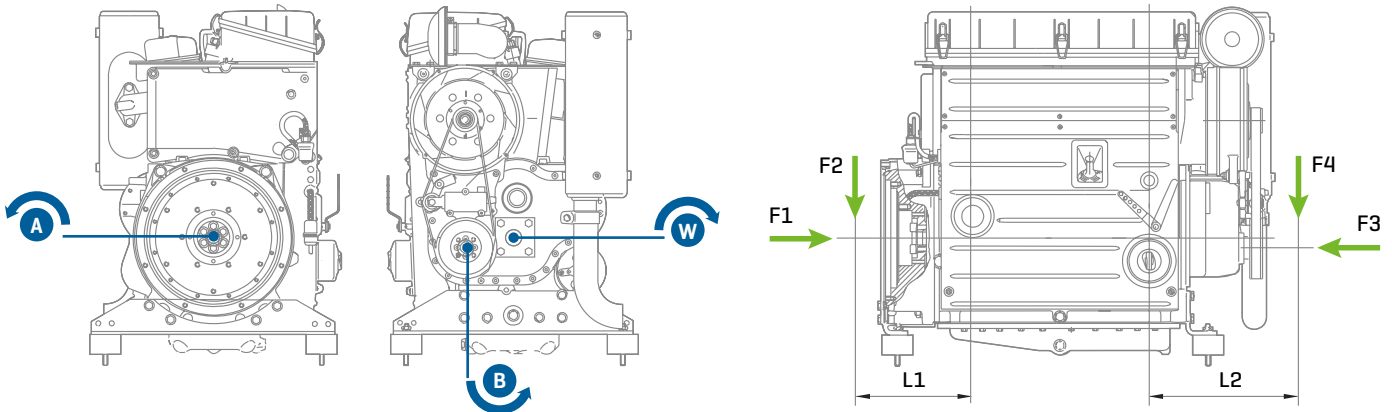

Power take off		2-4M41	4M42	3-4M43
Transmittable torque	A	Full torque	Full torque	Full torque
	B	32 Nm with engine speed	32 Nm with engine speed	32 Nm with engine speed
	W	70 Nm with engine speed	70 Nm with engine speed	70 Nm with engine speed
Permissible load	F1	2700 N	2700 N	2700 N
	F2	$F2 = \frac{400\,000}{L1(\text{mm}) - 73}$ [N]	$F2 = \frac{400\,000}{L1(\text{mm}) - 73}$ [N]	$F2 = \frac{400\,000}{L1(\text{mm}) - 73}$ [N]
	F3	1770 N	1770 N	1770 N
	F4	$F4 = \frac{228\,330}{L2(\text{mm}) - 76}$ [N]	$F4 = \frac{228\,330}{L2(\text{mm}) - 76}$ [N]	$F4 = \frac{228\,330}{L2(\text{mm}) - 76}$ [N]

Dimensions

2M41 | 3M41 | 4M41

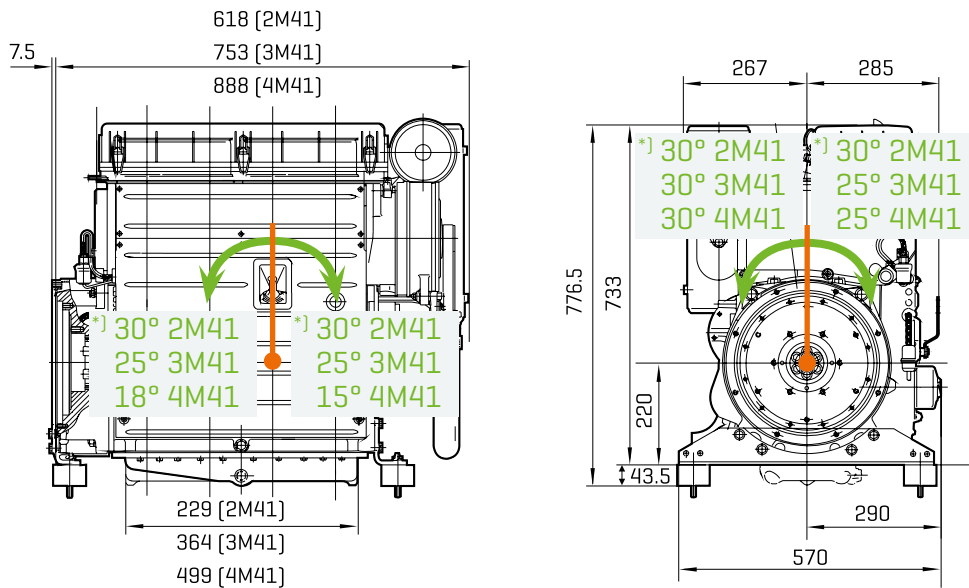

3M43 | 4M42 | 4M43

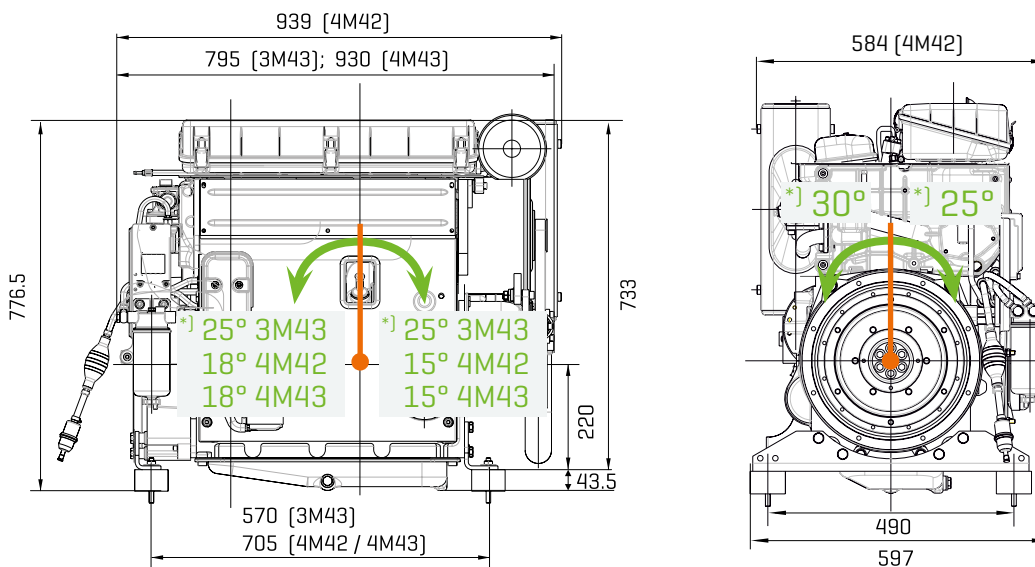

Flexible mounting is normally recommended for M series engines. This mounting keeps the noise level of the driven unit low. Another possibility is the flexible mounting with elevated engine brackets (not shown here). Rigid mounting is only possible up to an operating speed of 2300 rpm.

Diesel particulate filter (DPF)

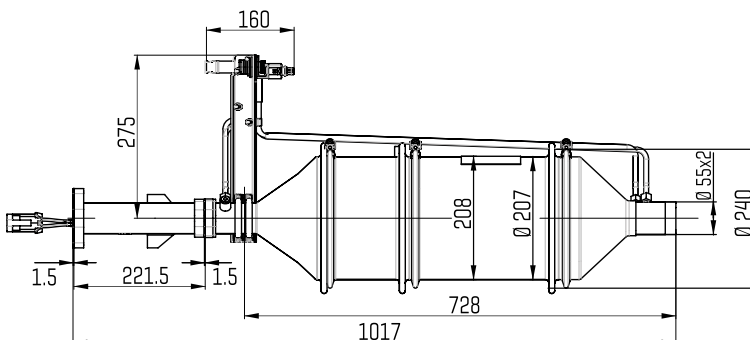

Spread of box dimensions ± 3 mm due to tolerance. Drawings with detail and connection dimensions as PDF and DXF can be found at www.hatz-diesel.com.

Dimensions 3M43 and 4M43 without DPF and exhaust muffler.

*] Max. tilt position

Motorenfabrik Hatz GmbH & Co. KG
Ernst-Hatz-Str. 16
94099 Ruhstorf a. d. Rott
Germany
Phone +49 8531 319-0
Fax +49 8531 319-418
marketing@hatz-diesel.de
www.hatz-diesel.com



CREATING POWER SOLUTIONS.

700 384 95 EN-07.16 Printed in Germany
Modifications, which serve the technical
improvements, are reserved.