



THE DEUTZ POWER PACK SERIES.

Product Overview.

The engine company.

FACTS.

It all started with one great idea more than 150 years ago. Nicolaus August Otto discovered the principle of the 4-stroke engine, thereby creating the basis for global motorisation and our mobile society.

DEUTZ Australia – Our origins.

It was the same year when he started with Eugen Langen 'N.A. Otto & Cie', the world's first engine factory – and the progenitor of today's DEUTZ AG.

Today, more than 800 sales and service partners provide our customers with support, 24 hours a day, 7 days a week, in 130 countries all over the world. 4,000 excellently trained and motivated DEUTZ employees provide you with support throughout the world at all times. Our state-of-the-art logistics centres boast around 80,000 parts and a sophisticated logistics system means that our spare parts can be promptly supplied to our customers and dealers around the world.

Since 1952, supported by a large dealer network, DEUTZ Australia Pty Ltd. has been offering these technologies, service, and knowledge throughout Australia, New Zealand and the Pacific Islands.

As the leading engine company in Australia, we are proud to present to you our latest innovation – DEUTZ DRIVE, which has been customised and exclusively built for the Australian and New Zealand markets.

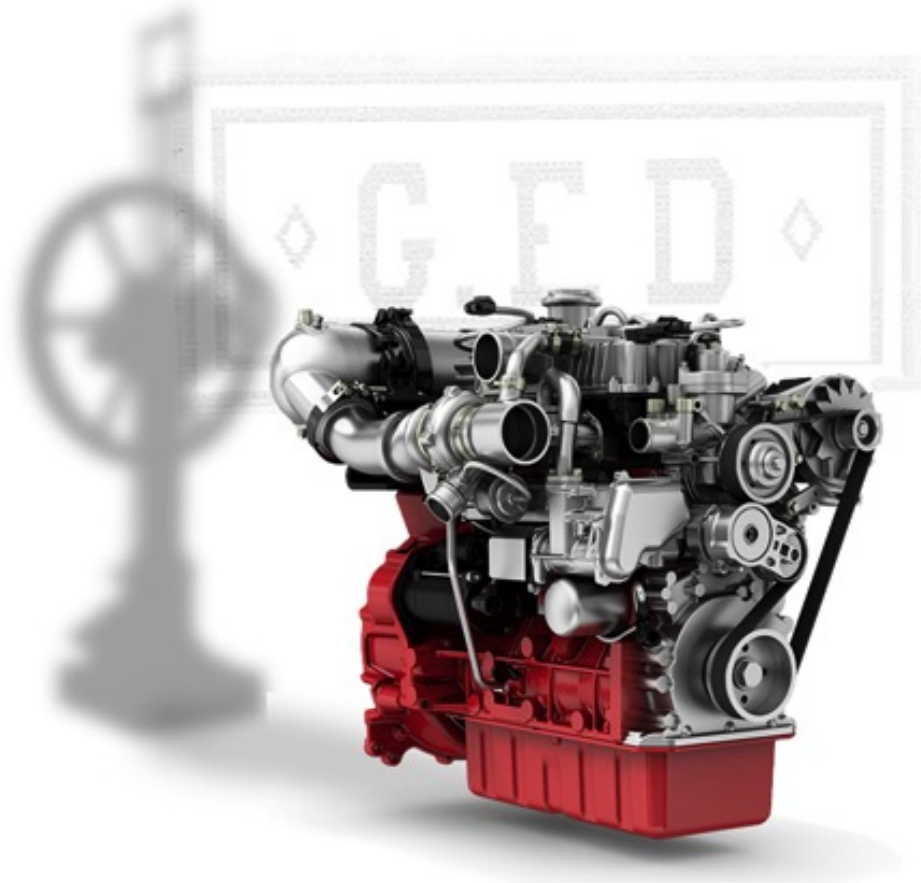

The engine company.

Innovative solutions for all applications.

As an independent manufacturer, DEUTZ offers a wide range of the most successful diesel and gas engine systems in the world. The engine range from 12kW to 620kW covers all areas of mobile and stationary applications.



Engine technology for tomorrow.

CONCEPT.

DEUTZ DRIVE is a new engine package that has been designed locally and specifically for the Australian and New Zealand market and conditions. This series includes the proven 912 and 914 air cooled engines, the 2011 air-oil cooled engines, and the 1013 water cooled engines to cover a wide range of applications.

DEUTZ can supply a Base Engine for general requirement and replacement, or a complete DEUTZ DRIVE turnkey Power Pack ready to install and run. The DEUTZ DRIVE is the perfect solution for reliable and fuel efficient motive power.

The driver of your success.

The benefits:

- Complete engine solutions for the majority of applications
- Compact designed engines with standardised components and exactly specified connection points
- Reduced installation work and cost allows a faster assembly time
- Frameless Power Pack solution offering customers maximum flexibility
- Flexible, modular, and simple system with a wide range of additional features
- Long-life engines with up to 3 years warranty
- Very economical thanks to low fuel consumption, long oil change intervals and low maintenance requirement

The engine company.

BASE ENGINE

Factory supplied scope:

- Mounted Engine Cooling System: integrated or externally
- Senders and Sensors: easy connection of the preferred engine control panel
- Mounted Manifold Muffler: mounted to all natural aspirated engines
- Mounted Air Cleaner: all natural aspirated and water cooled engines
- Engine Mounting: all engines come with rigid or flexible mountings
- Belt and Fan Guarding: all air-oil cooled engines are supplied with belt and fan guarding

DEUTZ DRIVE POWER PACK

Locally designed and manufactured value added options:

- Mounted Muffler: muffler, exhaust pipe, and mounting parts for all turbo charged engines
- Air Cleaner Mounting Kit: bracket, pipework, and connection parts for all 914 and 2011 turbo charged engines
- Belt and Fan Guarding: designed and manufactured according to AS4024 to cover the cooling fan and belts for all 912, 914, and 1013 engines

DEUTZ DRIVE CUSTOMISED OPTIONS

Solutions to suit any application:

- Engine Mounting: various flexible engine mounts
- Hayes Hydraulic Pump Drives
- Engine Speed Control: mechanical and electrical control
- Stub Shafts
- Engine Control Panels: basic protection, industrial, irrigation, auto control panels with various functions
- First Fill Options: recommended DEUTZ engine oil and coolant
- Hayes Sideload Kits
- PTO Clutches

DEUTZ DRIVE 2011 Series

2011 SERIES

- Air-Oil cooled engines with integrated cooling system
- 2 to 4 cylinder naturally aspirated and 4 cylinder turbo charged engines in inline arrangement
- High reliability combined with durability – no corrosion or cavitation due to oil cooling and lubrication



ENGINE DATA

ENGINE	F2L2011	F3L2011	F4L2011	BF4L2011
No. of cylinders	2	3	4	4
Power rating for interm. operations ¹	22.5 kW 30.2 hp	35.8 kW 48.0 hp	47.8 kW 64.1 hp	58.1 kW 77.9 hp
Power rating for cont. operations ²	21.8 kW 29.2 hp	34.0 kW 45.6 hp	45.5 kW 61.0 hp	55.1 kW 73.9 hp
Max. nominal speed	2800 rpm	2800 rpm	2800 rpm	2800 rpm
Specific fuel consumption ³	220 g/kWh	218 g/kWh	214 g/kWh	205 g/kWh
Adapter housing	SAE 4	SAE 4	SAE 4	SAE 4
Flywheel	SAE 8" / 10"	SAE 8" / 10"	SAE 8" / 10"	SAE 8" / 10"

1) For intermittent operations at max. nominal speed. According to ISO 3046-1 and with deduction of fan power

2) For continuous operations at max. nominal speed. According to ISO 3046-1 and with deduction of fan power

3) Best point consumption refers to diesel with a density of 0.835 kg/dm³ at 15°C

The engine company.

AIR-OIL COOLED ENGINES.

21.8 – 58.1 kW at 2800 rpm

POWER CURVES

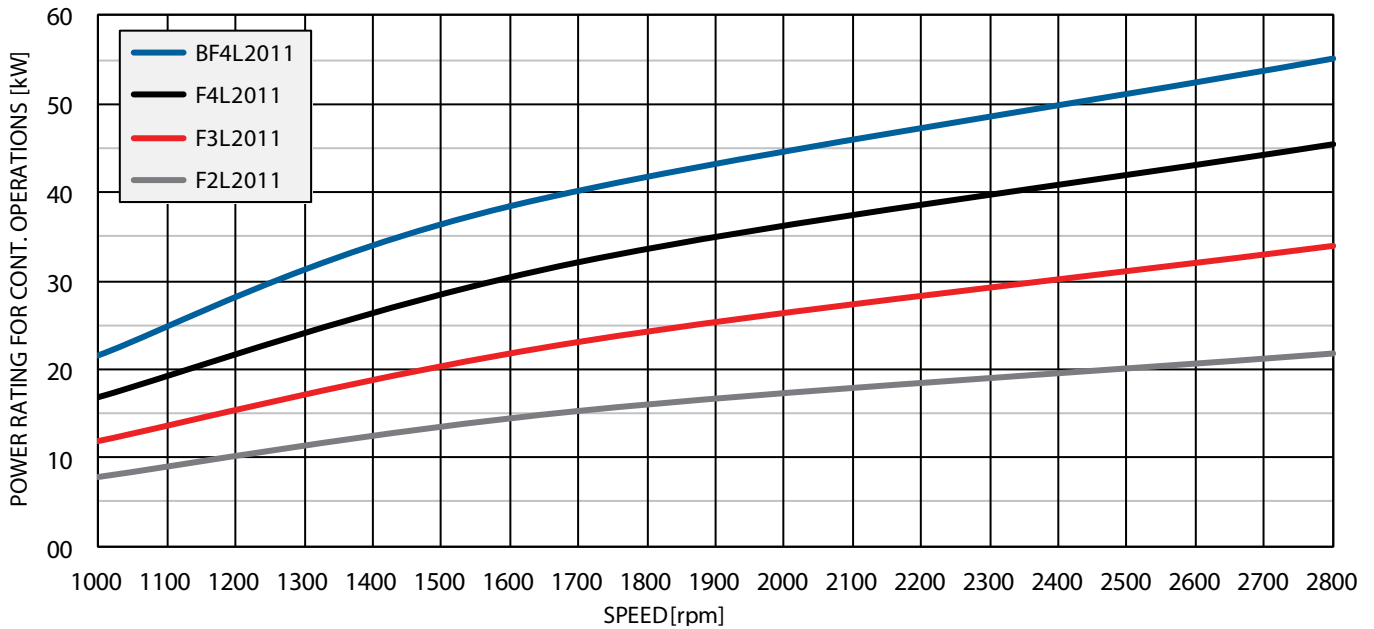

BASE ENGINE DIMENSIONS

ENGINE	F2L2011	F3L2011	F4L2011	BF4L2011 ¹
A	645 mm	756 mm	867 mm	777 mm
B	707 mm	701 mm	726 mm	718 mm
C	560 mm	560 mm	560 mm	534 mm
D	681 mm	681 mm	681 mm	674 mm
E	267 mm	267 mm	267 mm	267 mm
F	200 mm	200 mm	200 mm	200 mm

1) Dimensions without mounted air cleaner and silencers

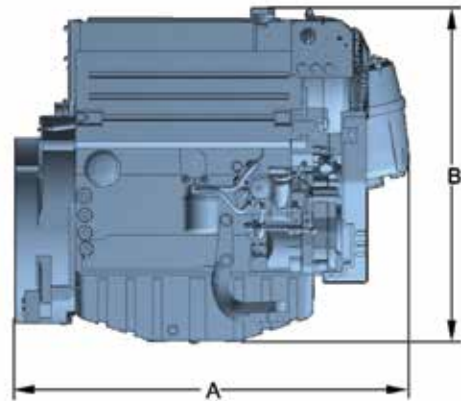
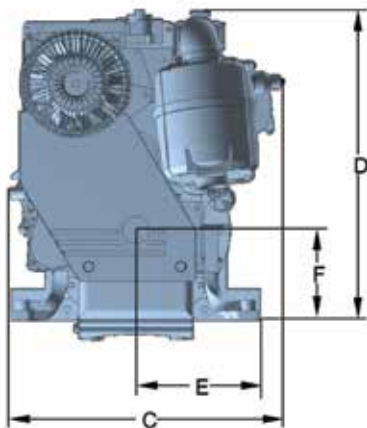

DEUTZ DRIVE 912 Series

912 SERIES

- Compact air cooled engines with integrated cooling system
- 3 to 6 cylinder naturally aspirated engines in inline arrangement
- Low maintenance costs due to individual cylinder heads and no external cooling system

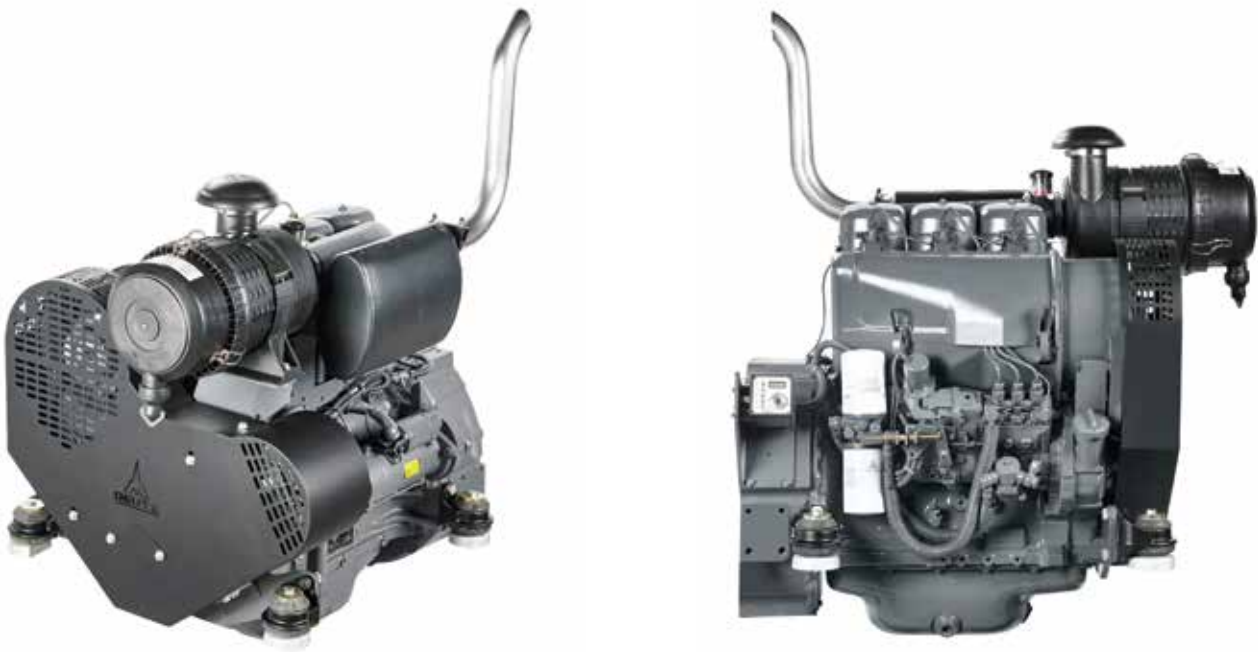

ENGINE DATA

ENGINE	F4L912	F6L912
No. of cylinders	4	6
Power rating for interm. operations ¹	51.0 kW 68.4 hp	78.0 kW 104.6 hp
Power rating for cont. operations ²	49.0 kW 65.7 hp	74.0 kW 99.2 hp
Max. nominal speed	2300 rpm	2300 rpm
Specific fuel consumption ³	215 g/kWh	215 g/kWh
Adapter housing	SAE 3	SAE 3
Flywheel	SAE 8" / 10"	SAE 10" / 11.5"

1) For intermittent operations at max. nominal speed. According to ISO 3046-1 and with deduction of fan power

2) For continuous operations at max. nominal speed. According to ISO 3046-1 and with deduction of fan power

3) Best point consumption refers to diesel with a density of 0.835 kg/dm³ at 15°C

The engine company.

AIR COOLED ENGINES.

49.0 – 78.0 kW at 2300 rpm

POWER CURVES

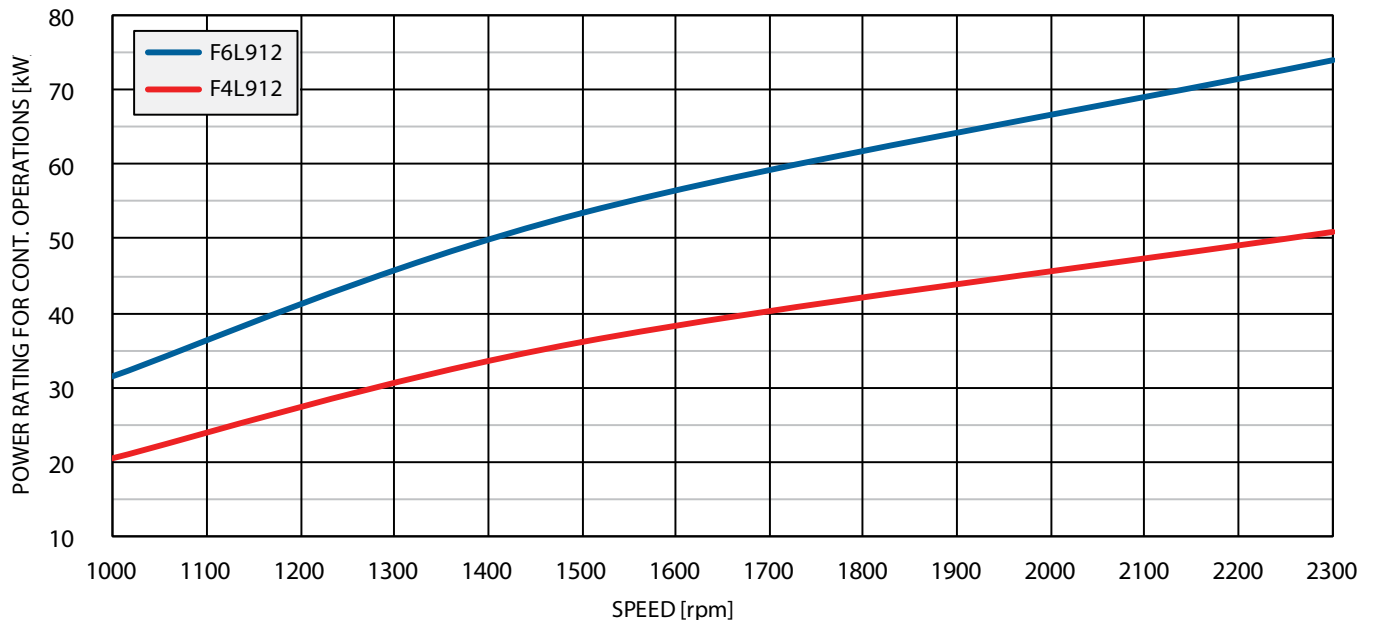

BASE ENGINE DIMENSIONS

ENGINE	F4L912	F6L912
A	1084 mm	1443 mm
B	939 mm	949 mm
C	690 mm	690 mm
D	774 mm	774 mm
E	345 mm	345 mm
F	100 mm	100 mm

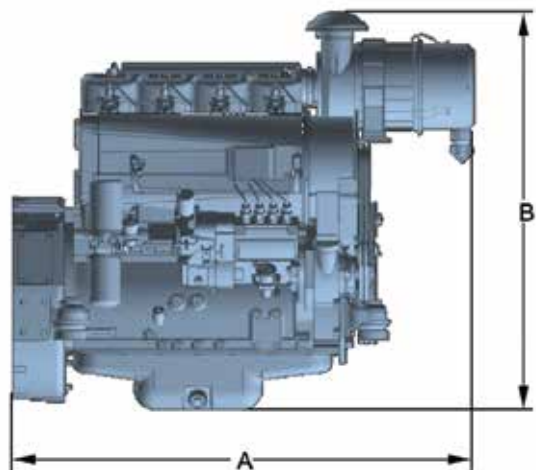
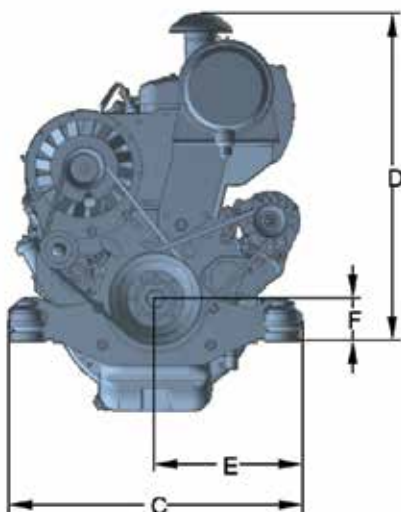

DEUTZ DRIVE 914 Series

914 SERIES

- Compact air cooled engines with integrated cooling system
- 4 and 6 cylinder naturally aspirated and turbo charged engines in inline arrangement
- Low maintenance costs due to individual cylinder heads and no external cooling system



ENGINE DATA

ENGINE	F4L914	BF4L914	F6L914	BF6L914
No. of cylinders	4	4	6	6
Power rating for intern. operations ¹	60.0 kW 80.5 hp	78.0 kW 97.9 hp	90.5 kW 121.4 hp	129.0 kW 173.0 hp
Power rating for cont. operations ²	57.0 kW 76.4 hp	73.0 kW 104.6 hp	86.0 kW 115.3 hp	120.0 kW 160.9 hp
Max. nominal speed	2300 rpm	2300 rpm	2300 rpm	2300 rpm
Specific fuel consumption ³	215 g/kWh	210 g/kWh	215 g/kWh	208 g/kWh
Adapter housing	SAE 3	SAE 3	SAE 3	SAE 3
Flywheel	SAE 8" / 10"	SAE 10" / 11.5"	SAE 10" / 11.5"	SAE 10" / 11.5"

1) For intermittent operations at max. nominal speed. According to ISO 3046-1 and with deduction of fan power

2) For continuous operations at max. nominal speed. According to ISO 3046-1 and with deduction of fan power

3) Best point consumption refers to diesel with a density of 0.835 kg/dm³ at 15°C

The engine company.

AIR COOLED ENGINES.

57.0 – 129.0 kW at 2300 rpm

POWER CURVES

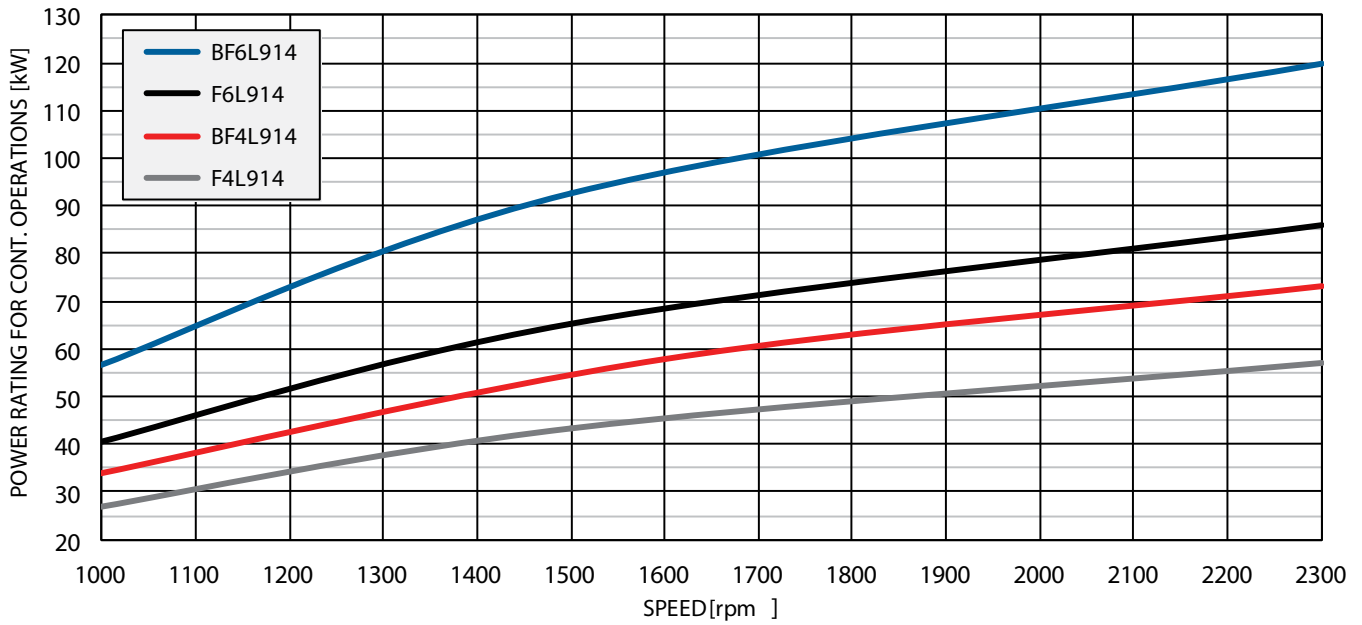

BASE ENGINE DIMENSIONS

ENGINE	F4L914	BF4L914 ¹	F6L914	BF6L914 ¹
A	1103 mm	910 mm	1443 mm	1319 mm
B	939 mm	838 mm	949 mm	875 mm
C	690 mm	690 mm	690 mm	708 mm
D	774 mm	673 mm	774 mm	694 mm
E	345 mm	345 mm	345 mm	345 mm
F	100 mm	100 mm	100 mm	100 mm

1) Dimensions without mounted air cleaner and silencers

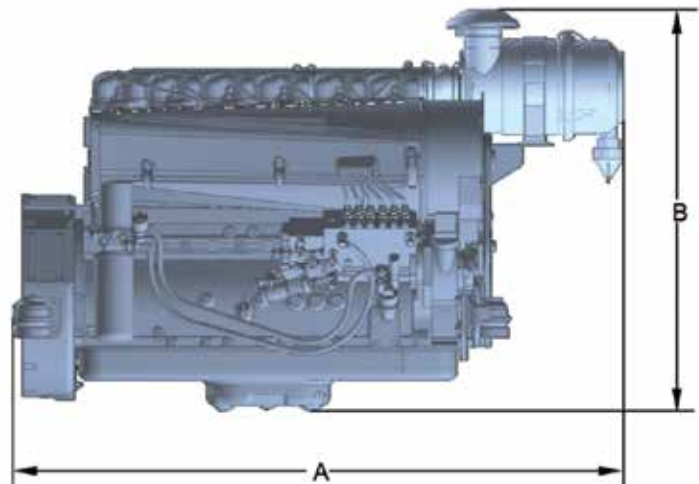
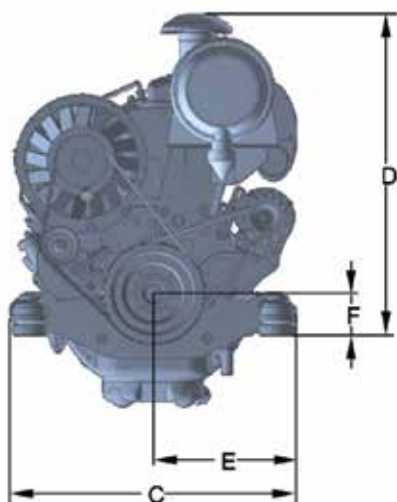

DEUTZ DRIVE 1013 Series

1013 SERIES

- Water cooled engines with externally mounted cooling system
- 4 and 6 cylinder turbo charged inline engines with charge air cooling option
- Reduced running and service costs due to wet cylinder liners and long oil change intervals

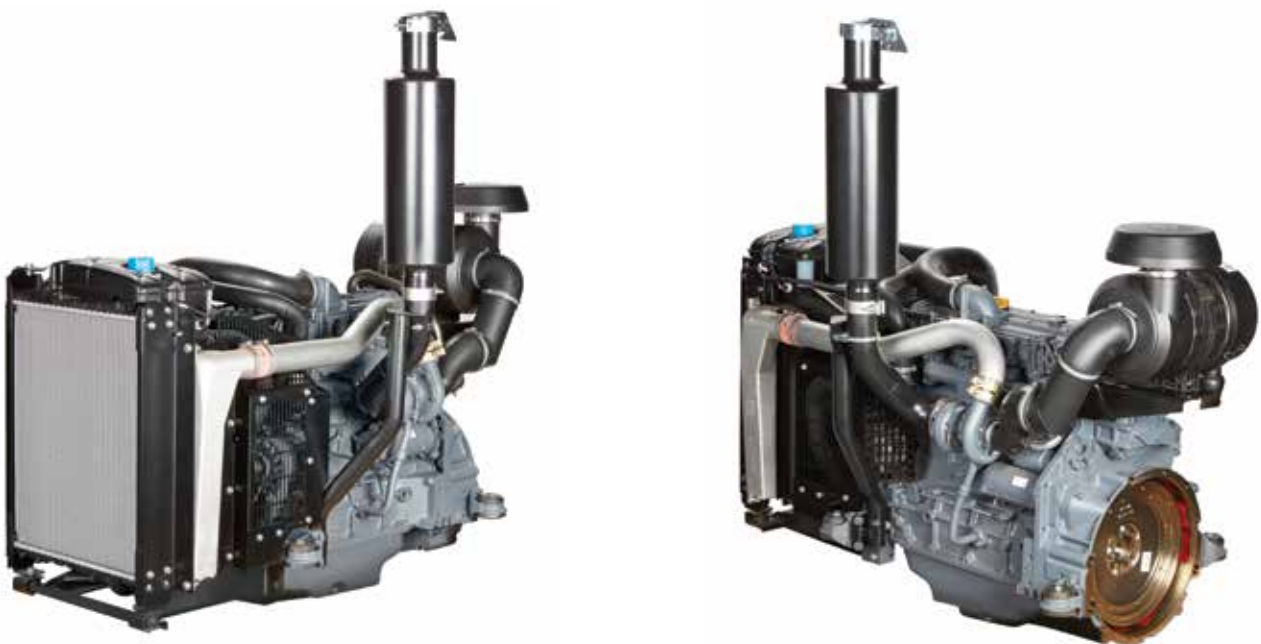

ENGINE DATA

ENGINE	BF4M1013 E	BF4M1013 EC	BF6M1013 E	BF6M1013 EC	BF6M1013 FC
No. of cylinders	4	4	6	6	6
Power rating for interm. operations ¹	90.0 kW 120.1 hp	115.0 kW 154.2 hp	137.0 kW 183.7 hp	165.0 kW 221.3 hp	175.0 kW 234.7 hp
Power rating for cont. operations ²	86.0 kW 115.3 hp	107.0 kW 143.5 hp	130.0 kW 174.3 hp	157.0 kW 210.5 hp	165.0 kW 221.3 hp
Max. nominal speed	2300 rpm	2300 rpm	2300 rpm	2300 rpm	1800 rpm
Specific fuel consumption ³	205 g/kWh	205 g/kWh	205 g/kWh	205 g/kWh	205 g/kWh
Adapter housing	SAE 3	SAE 3	SAE 3	SAE 3	SAE 3
Flywheel	SAE 10" / 11.5"	SAE 10" / 11.5"	SAE 10" / 11.5"	SAE 10" / 11.5"	SAE 10" / 11.5"

1) For intermittent operations at max. nominal speed. According to ISO 3046-1 and without deduction of fan power

2) For continuous operations at max. nominal speed. According to ISO 3046-1 and without deduction of fan power

3) Best point consumption refers to diesel with a density of 0.835 kg/dm³ at 15°C

The engine company.

WATER COOLED ENGINES.

86.0 – 165.0 kW at 2300 rpm

POWER CURVES

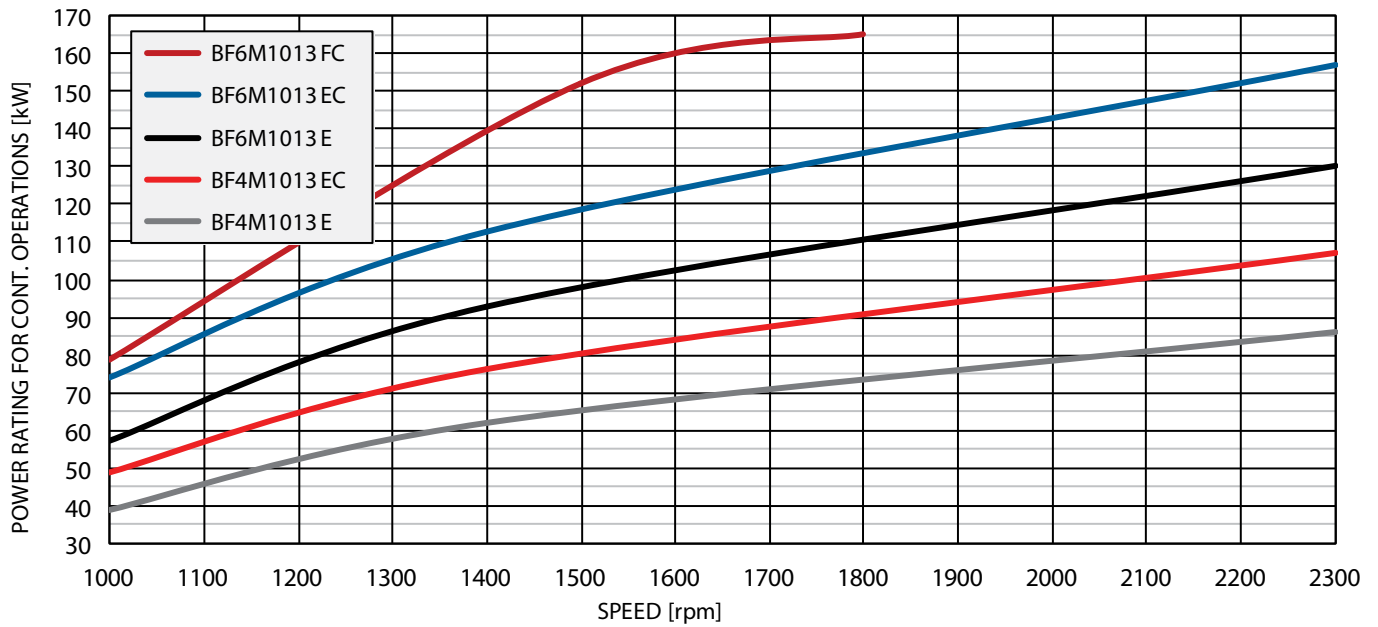

BASE ENGINE DIMENSIONS

ENGINE	BF4M1013 E	BF4M1013 EC	BF6M1013 E	BF6M1013 EC	BF6M1013 FC
A	1430 mm	1547 mm	1712 mm	1881 mm	1881 mm
B	1151 mm	1151 mm	1239 mm	1239 mm	1239 mm
C	690 mm	732 mm	748 mm	873 mm	873 mm
D	956 mm	956 mm	994 mm	994 mm	994 mm
E	345 mm	345 mm	345 mm	345 mm	345 mm
F	100 mm	100 mm	100 mm	100 mm	100 mm

All dimensions are without mounted silencers

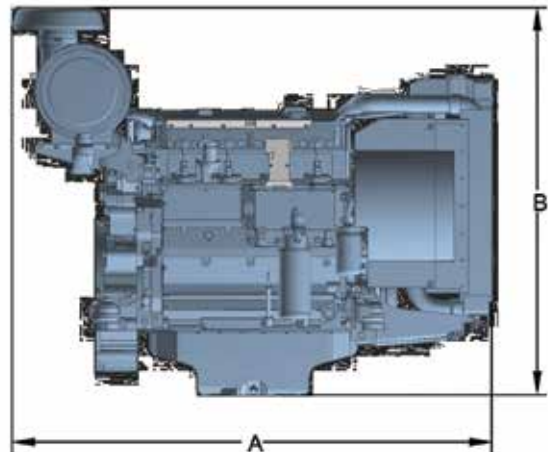
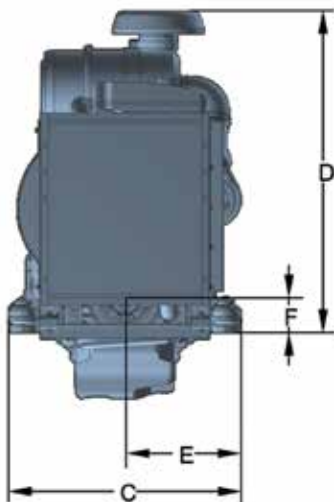

DEUTZ DRIVE TCD 2013 L06 2V

TCD 2013 L06 2V

- Water-cooled 6-cylinder inline engine with turbocharging and charge air cooling
- The powerful DEUTZ Common-Rail (DCR®) injection system and the electronic engine control (EMR 3) with intelligent link to the drive management ensure optimum engine performance at low fuel consumption
- Best cold starting properties even under extreme conditions
- Low noise emissions due to acoustically optimised components with very smooth running and high durability
- The compact engine design and three PTO drive possibilities integrated into the gear drive reduce the installation costs and increase the number of applications
- Wet cylinder liners, long oil change intervals and easy changing of the engine fluids reduce the running and service costs and increase the availability of the machinery
- The robust engine design allows world- wide operation even with high sulphur fuels

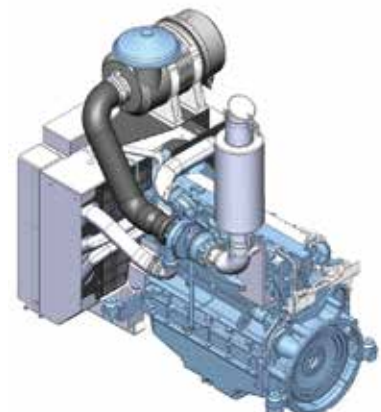
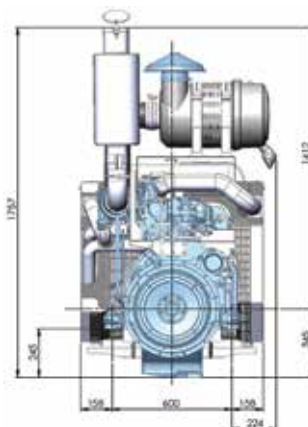
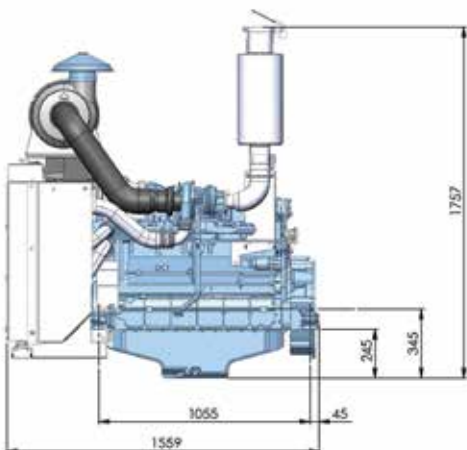

The engine company.

ENGINE DATA

ENGINE TYPE	UNITS	TCD 2013 L6 2V
No. of cylinders		6
Bore/stroke	mm in	108/130 4.3/5.1
Capacity	l cu in	7.2 439.4
Compression ratio		18.1:1
Nominal speeds	min-1 rpm	1800-2300
Power output	kW hp	190 254
At speed	min-1 rpm	2300
Max. torque	Nm lb/ft	1000 737.5
At speed	min-1 rpm	1500
Minimum idling speed	min-1 rpm	650
Specific fuel consumption	g/kWh lb/hph	205 0.337
Weight (approx.)	Kg/lb	810/1786

POWER CURVE

ENGINE TYPE TCD2013 L06 2V
 STANDARD Power category II
 RATED POWER 190 kW at 2300 rpm
 MAX. TORQUE 1000 Nm at 1500 rpm

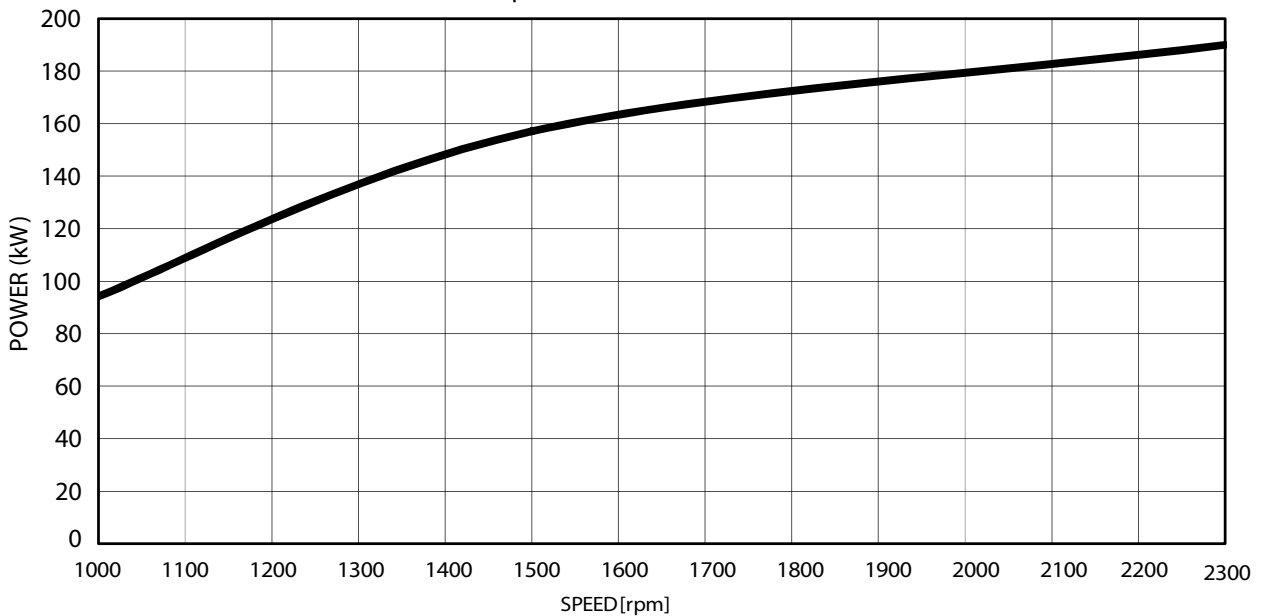

ENGINE DATA

TCD 2013 SERIES POWER RATING							
ENGINE TYPE	COOLING MEDIUM	POWER RATING FOR CONT OP	NOMINAL SPEED	MOUNTED COOLER	MOUNTED SILENCER	MOUNTED AIR CLEANER	GUARDING (AS4024)
TCD2013L06 2V	Water	190kW	2300 rpm	▲	▲	▲	▲

DEUTZ DRIVE BFM1015 C & BFM1015 CP

BFM1015 C and BFM1015 CP

- Water-cooled V6 and V8 engines with turbocharging, charge air cooling and four-valve technology.
- Very compact engine design reduces the installation costs.
- Wet cylinder liners, long oil change intervals and easy changing of the engine fluids reduce the running and service costs and increase the availability of the machinery.
- Best cold starting performance even under extreme conditions.
- Robust and reliable mechanical injection system.
- Also available with an electronic motor regulator (EMR) to allow easy integration into the electronic device control and monitoring system.
- Low noise emissions due to acoustically optimized components with very smooth running and high durability.
- The robust engine design allows worldwide operation even with high sulphur fuels

ENGINE DATA

1015 SERIES POWER RATINGS							
ENGINE TYPE	COOLING MEDIUM	POWER RATING FOR CONT OP	NOMINAL SPEED	MOUNTED COOLER	MOUNTED SILENCER	MOUNTED AIR CLEANER	GUARDING (AS4024)
BF6M1015 C	Water	273 kW	2100 rpm	▲	▲	▲	▲
BF6M1015 CP	Water	300 kW	2100 rpm	▲	▲	▲	▲
BF8M1015 C	Water	364 kW	2100 rpm	▲	▲	▲	▲
BF8M1015 CP	Water	400 kW	2100 rpm	▲	▲	▲	▲

POWER CURVES

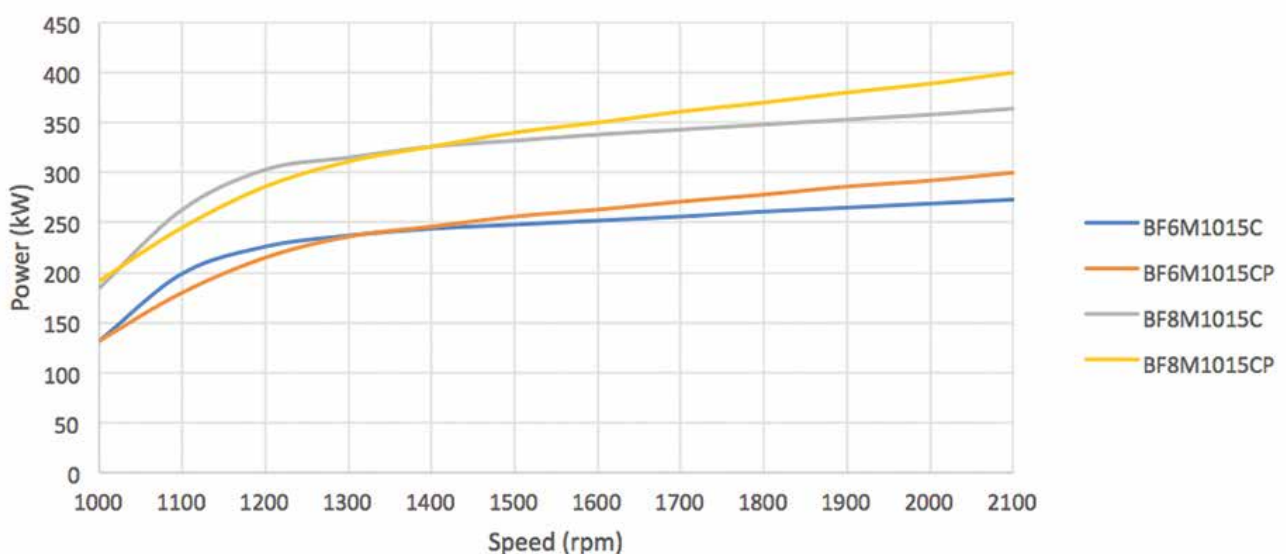

The engine company.

ENGINE DIMENSIONS

1015 SERIES DIMENSIONS				
ENGINE	BF6M1015 C	BF6M1015 CP	BF8M1015 C	BF8M1015 CP
A	1763 mm	1763 mm	2073 mm	2073 mm
B	2056 mm	2056 mm	2056 mm	2056 mm
C	1284 mm	1284 mm	1284 mm	1284 mm
D	1016 mm	1016 mm	1016 mm	1016 mm
E	508 mm	508 mm	508 mm	508 mm

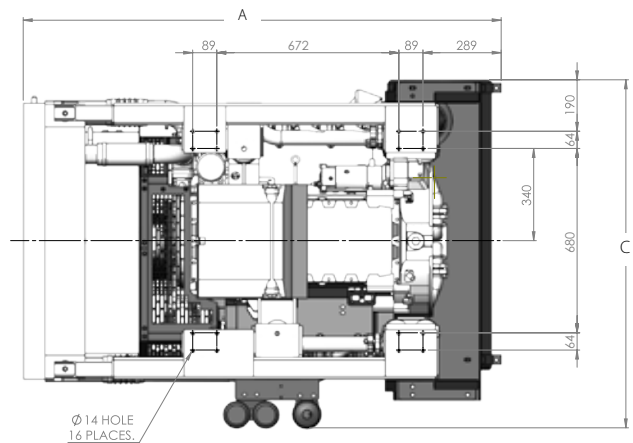
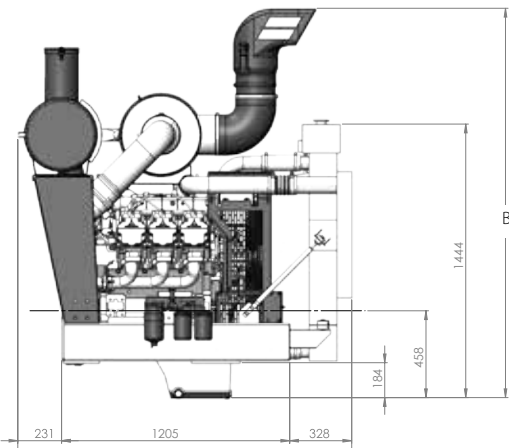
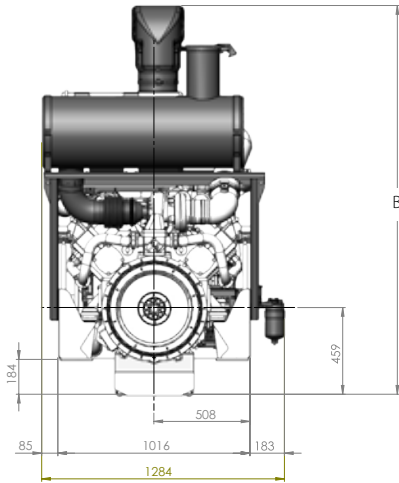
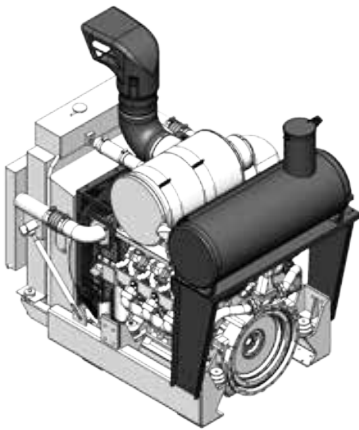

BF6M1015 C and BF6M1015 CP Power Pack dimensions are shown

OVERVIEW.

ENGINE TYPE	COOLING MEDIUM	POWER RATING FOR CONT. OPERATIONS	NOMINAL SPEED	MOUNTED COOLER	MOUNTED SILENCER	MOUNTED AIR CLEANER	GUARDING (AS4024)
F2L2011	Air - Oil	21.8 kW	2800 rpm	▲	▲	▲	▲
F3L2011	Air - Oil	34.0 kW	2800 rpm	▲	▲	▲	▲
F4L2011	Air - Oil	45.4 kW	2800 rpm	▲	▲	▲	▲
BF4L2011	Air - Oil	55.1 kW	2800 rpm	▲	◆	◆	▲
F3L912	Air	36.0 kW	2300 rpm		▲	▲	◆
F4L912	Air	49.0 kW	2300 rpm		▲	▲	◆
F4L914	Air	57.0 kW	2300 rpm		▲	▲	◆
F5L912	Air	61.0 kW	2300 rpm		▲	▲	◆
BF4L914	Air	73.0 kW	2300 rpm		◆	◆	◆
F6L912	Air	74.0 kW	2300 rpm		▲	▲	◆
F6L914	Air	86.0 kW	2300 rpm		▲	▲	◆
BF6L914	Air	120.0 kW	2300 rpm		◆	◆	◆
BF4M1013 E	Water	86.0 kW	2300 rpm	▲	◆	▲	◆
BF4M1013 EC	Water	107.0 kW	2300 rpm	▲	◆	▲	◆
BF6M1013 E	Water	130.0 kW	2300 rpm	▲	◆	▲	◆
BF6M1013 EC	Water	157.0 kW	2300 rpm	▲	◆	▲	◆
BF6M1013 FC	Water	165.0 kW	1800 rpm	▲	◆	▲	◆
TCD 2013 06 2V	Water	190kW	2300rpm	▲	◆	◆	◆
BF6M1015 C	Water	300kW	2100rpm	▲	◆	◆	◆
BF6M1015 CP	Water	330kW	2100rpm	▲	◆	◆	◆
BF8M1015 C	Water	400kW	2100rpm	▲	◆	◆	◆
BF8M1015 CP	Water	440kW	2100rpm	▲	◆	◆	◆

▲ BASE ENGINE

◆ DEUTZ DRIVE POWER PACK

● DEUTZ DRIVE OPTION

The engine company.

FLEXIBLE ENGINE MOUNTS	RIGID ENGINE MOUNTS	HYDRAULIC PUMP DRIVE	SPEED CONTROL	STUB SHAFT	PROTECTION PANEL	INDUSTRIAL PANEL	IRRIGATION PANEL	FIRST ENGINE FILL
●	▲	●	●	●	●	●	●	●
●	▲	●	●	●	●	●	●	●
●	▲	●	●	●	●	●	●	●
●	▲	●	●	●	●	●	●	●
▲	●	●	●	●	●	●	●	●
▲	●	●	●	●	●	●	●	●
▲	●	●	●	●	●	●	●	●
▲	●	●	●	●	●	●	●	●
▲	●	●	●	●	●	●	●	●
▲	●	●	●	●	●	●	●	●
▲	●	●	●	●	●	●	●	●
▲	●	●	●	●	●	●	●	●
▲	●	●	●	●	●	●	●	●
▲	●	●	●	●	●	●	●	●
▲	●	●	●	●	●	●	●	●
▲	●	●	●	●	●	●	●	●
▲	●	●	●	●	●	●	●	●
▲	◆	◆	◆	◆	◆	◆	◆	◆
▲	◆	◆	◆	◆	◆	◆	◆	◆
▲	◆	◆	◆	◆	◆	◆	◆	◆
▲	◆	◆	◆	◆	◆	◆	◆	◆
▲	◆	◆	◆	◆	◆	◆	◆	◆



For more information please contact your local DEUTZ Dealer.